



Product Specification

AU OPTRONICS CORPORATION

() Preliminary Specifications

(V) Final Specifications

Module	13.3”(13.25”) HD 16:9 Color TFT-LCD with LED Backlight design
Model Name	B133XW03 V3 (H/W:0A)
Note 	<i>LED Backlight with driving circuit design</i> ✓ <i>Color Management (Virtual and Rich Color Solution)</i> ✓ <i>Dynamic Contrast Ratio (Power Saving Solution)</i>

Customer	Date
Checked & Approved by	Date
Note: This Specification is subject to change without notice.	

Approved by	Date
<u>Howard LEE</u>	<u>04/14/2010</u>
Prepared by	
<u>YW LEE</u>	<u>04/14/2010</u>
NBBU Marketing Division AU Optronics corporation	



Contents

- 1. Handling Precautions 4**
- 2. General Description 5**
 - 2.1 General Specification 5
 - 2.2 Optical Characteristics 6
- 3. Functional Block Diagram 11**
- 4. Absolute Maximum Ratings..... 12**
 - 4.1 Absolute Ratings of TFT LCD Module 12
 - 4.2 Absolute Ratings of Environment 12
- 5. Electrical Characteristics..... 13**
 - 5.1 TFT LCD Module..... 13
 - 5.2 Backlight Unit 16
- 6. Signal Interface Characteristic..... 17**
 - 6.1 Pixel Format Image 17
 - 6.2 The Input Data Format 18
 - 6.3 Integration Interface Requirement..... 19
 - 6.4 Interface Timing 21
 - 6.5 Power ON/OFF Sequence 22
- 7. Panel Reliability Test 23**
 - 7.1 Vibration Test 23
 - 7.2 Shock Test 23
 - 7.3 Reliability Test..... 23
- 8. Mechanical Characteristics..... 24**
 - 8.1 LCM Outline Dimension..... 24
- 9. Shipping and Package 26**
 - 9.1 Shipping Label Format 26
 - 9.2 Carton Package..... 27
 - 9.3 Shipping Package of Palletizing Sequence..... 27
- 10. Appendix..... 28**
 - 10.1 EDID Description..... 28
 - 10.2 Color Standardization Photographs..... 32



Product Specification

AU OPTRONICS CORPORATION

Record of Revision

Version and Date	Page	Old description	New Description	Remark
0.1 2009/12/03	All	First Edition for Customer		
0.2 2010/02/10	6	TBD	Add RGB spec.	
0.1 2010/04/14	All	Final Edition for Customer		

1. Handling Precautions

- 1) Since front polarizer is easily damaged, pay attention not to scratch it.
- 2) Be sure to turn off power supply when inserting or disconnecting from input connector.
- 3) Wipe off water drop immediately. Long contact with water may cause discoloration or spots.
- 4) When the panel surface is soiled, wipe it with absorbent cotton or other soft cloth.
- 5) Since the panel is made of glass, it may break or crack if dropped or bumped on hard surface.
- 6) Since CMOS LSI is used in this module, take care of static electricity and insure human earth when handling.
- 7) Do not open nor modify the Module Assembly.
- 8) Do not press the reflector sheet at the back of the module to any directions.
- 9) At the insertion or removal of the Signal Interface Connector, be sure not to rotate nor tilt the Interface Connector of the TFT Module.
- 11) After installation of the TFT Module into an enclosure (Notebook PC Bezel, for example), do not twist nor bend the TFT Module even momentary. At designing the enclosure, it should be taken into consideration that no bending/twisting forces are applied to the TFT Module from outside. Otherwise the TFT Module may be damaged.
- 12) Small amount of materials having no flammability grade is used in the LCD module. The LCD module should be supplied by power complied with requirements of Limited Power Source (IEC60950 or UL1950), or be applied exemption.
- 13) Disconnecting power supply before handling LCD modules, it can prevent electric shock, DO NOT TOUCH the electrode parts, cables, connectors and LED circuit part of TFT module that a LED light bar build in as a light source of back light unit. It can prevent electrostatic breakdown.

2. General Description

B133XW03 V3 is a Color Active Matrix Liquid Crystal Display composed of a TFT LCD panel, a driver circuit, and LED backlight system. The screen format is intended to support the 16:9 HD, 1366(H) x768(V) screen and 262k colors (RGB 6-bits data driver) with LED backlight driving circuit. All input signals are LVDS interface compatible.

B133XW03 V3 is designed for a display unit of notebook style personal computer and industrial machine.

2.1 General Specification

The following items are characteristics summary on the table at 25 °C condition:

Items	Unit	Specifications			
Screen Diagonal	[mm]	336.6 (13.25W")			
Active Area	[mm]	293.42 X 164.97			
Pixels H x V		1366x3(RGB) x 768			
Pixel Pitch	[mm]	0.2148X0.2148			
Pixel Format		R.G.B. Vertical Stripe			
Display Mode		Normally White			
White Luminance (ILED=20mA) (Note: ILED is LED current)	[cd/m ²]	200 typ. (5 points average) 170 min. (5 points average)			
Luminance Uniformity		1.25 max. (5 points)			
Contrast Ratio		400 typ, 300 min.			
Response Time	[ms]	8 typ / 16 Max			
Nominal Input Voltage VDD	[Volt]	+3.3 typ.			
Power Consumption	[Watt]	3.0 max. (Include Logic and Blu power)			
Weight	[Grams]	310 max.			
Physical Size Include bracket	[mm]		Min.	Typ.	Max.
		Length	316.7	317.2	317.7
		Width	188.2	188.7	189.2
		Thickness	-	-	3.6
Electrical Interface		1 channel LVDS			
Glass Thickness	[mm]	0.5			
Surface Treatment		AG, Hardness 3H			
Support Color		262K colors (RGB 6-bit)			



Product Specification

AU OPTRONICS CORPORATION

Temperature Range Operating	[°C]	0 to +50
Storage (Non-Operating)	[°C]	-20 to +60
RoHS Compliance		RoHS Compliance

2.2 Optical Characteristics

The optical characteristics are measured under stable conditions at 25°C (Room Temperature) :

Item	Symbol	Conditions	Min.	Typ.	Max.	Unit	Note				
White Luminance $I_{LED=20mA}$		5 points average	170	200	-	cd/m ²	1, 4, 5.				
Viewing Angle	θ_R	Horizontal (Right) CR = 10 (Left)	40	45	-	degree	4, 9				
	θ_L		40	45	-						
	ϕ_H	Vertical (Upper) CR = 10 (Lower)	10	15	-						
	ϕ_L		30	35	-						
Luminance Uniformity	δ_{5P}	5 Points	-	-	1.25		1, 3, 4				
Luminance Uniformity	δ_{13P}	13 Points	-	-	1.50		2, 3, 4				
Contrast Ratio	CR		400	500	-		4, 6				
Cross talk	%				4		4, 7				
Response Time	T_{RT}	Rising + Falling	-	8	16	msec	4, 8				
Color / Chromaticity Coordinates	Red	Rx	CIE 1931	0.560	0.590	0.620		4			
		Ry		0.315	0.345	0.375					
	Green	Gx		0.295	0.325	0.355					
		Gy		0.510	0.540	0.570					
	Blue	Bx		0.120	0.150	0.180					
		By		0.115	0.145	0.175					
	White	Wx		0.283	0.313	0.343					
		Wy		0.299	0.329	0.359					
	NTSC	%			-	45			-		

Note 1: 5 points position (Ref: Active area)

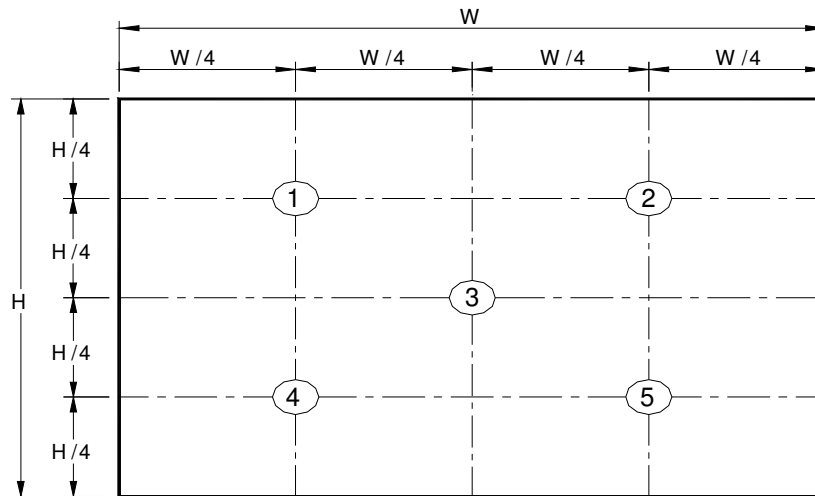

Note 2: 13 points position (Ref: Active area)

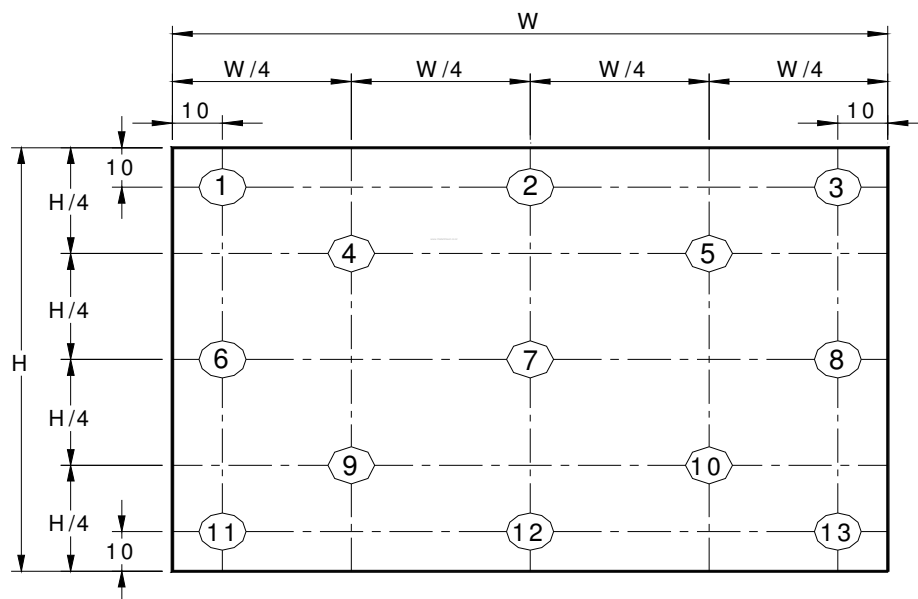

Note 3: The luminance uniformity of 5 or 13 points is defined by dividing the maximum luminance values by the minimum test point luminance

$$\delta_{w5} = \frac{\text{Maximum Brightness of five points}}{\text{Minimum Brightness of five points}}$$

$$\delta_{w13} = \frac{\text{Maximum Brightness of thirteen points}}{\text{Minimum Brightness of thirteen points}}$$

Note 4: Measurement method

The LCD module should be stabilized at given temperature for 30 minutes to avoid abrupt temperature change during measuring. In order to stabilize the luminance, the measurement should be executed after lighting

Backlight for 30 minutes in a stable, windless and dark room, and it should be measured in the center of screen.

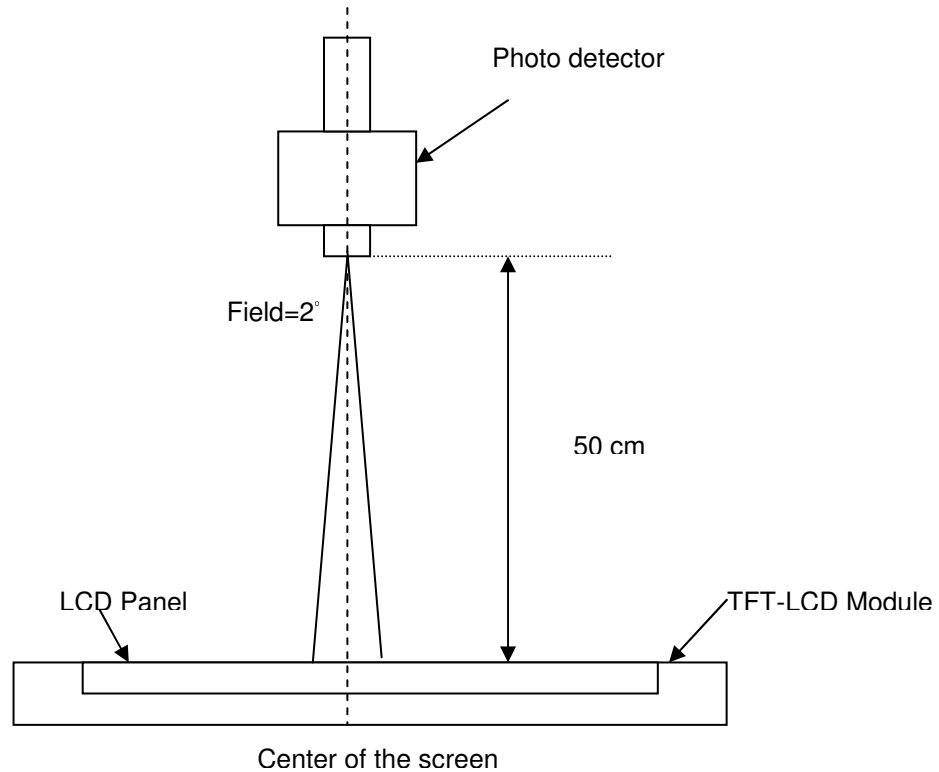

Note 5 : Definition of Average Luminance of White (Y_L):

Measure the luminance of gray level 63 at 5 points · $Y_L = [L(1) + L(2) + L(3) + L(4) + L(5)] / 5$

$L(x)$ is corresponding to the luminance of the point X at Figure in Note (1).

Note 6 : Definition of contrast ratio:

Contrast ratio is calculated with the following formula.

$$\text{Contrast ratio (CR)} = \frac{\text{Brightness on the "White" state}}{\text{Brightness on the "Black" state}}$$

Note 7 : Definition of Cross Talk (CT)

$$CT = |Y_B - Y_A| / Y_A \times 100 (\%)$$

Where

Y_A = Luminance of measured location without gray level 0 pattern (cd/m^2)

Y_B = Luminance of measured location with gray level 0 pattern (cd/m^2)

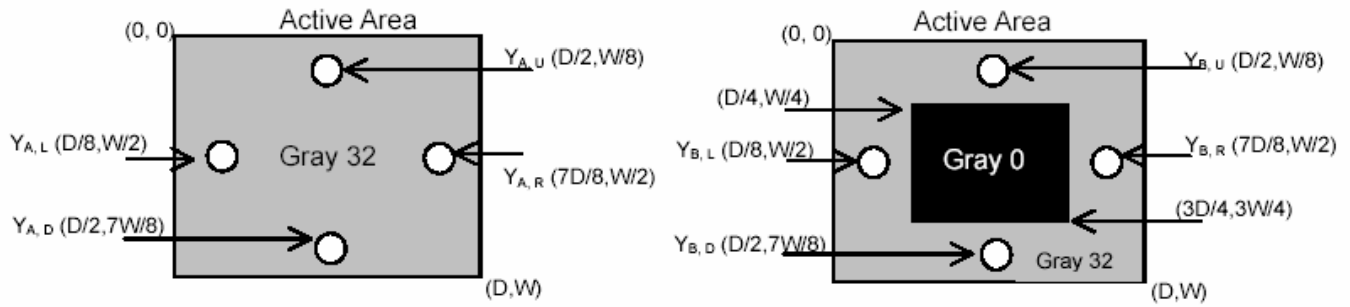

Note 8: Definition of response time:

The output signals of BM-7 or equivalent are measured when the input signals are changed from "Black" to "White" (falling time) and from "White" to "Black" (rising time), respectively. The response time interval between the 10% and 90% of amplitudes. Refer to figure as below.

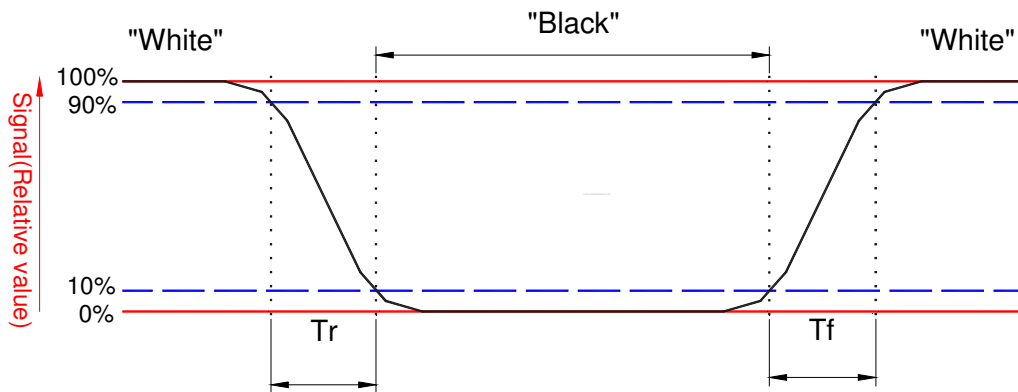

Note 9. Definition of viewing angle

Viewing angle is the measurement of contrast ratio ≥ 10 , at the screen center, over a 180° horizontal and 180° vertical range (off-normal viewing angles). The 180° viewing angle range is broken down as follows; 90° (θ) horizontal left and right and 90° (ϕ) vertical, high (up) and low (down). The measurement direction is typically perpendicular to the display surface with the screen rotated about its center to develop the desired measurement viewing angle.

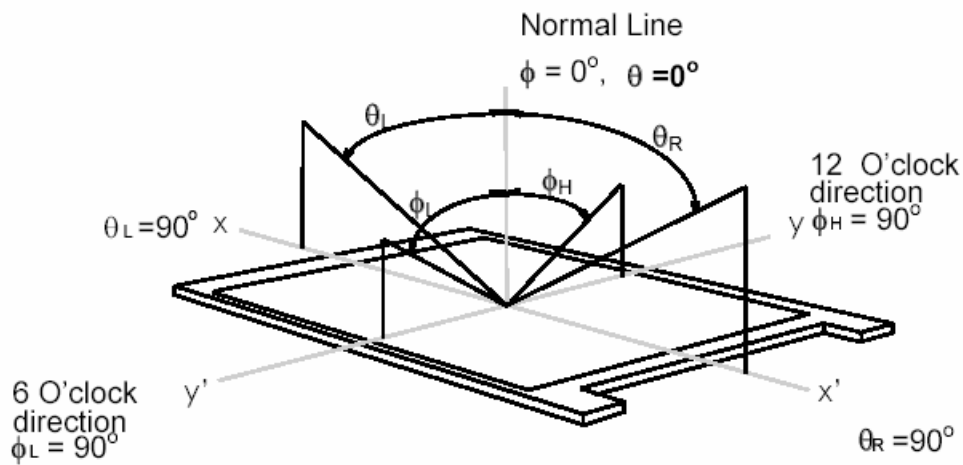

3. Functional Block Diagram

The following diagram shows the functional block of the 13.3 inches wide Color TFT/LCD 40 Pin one channel Module

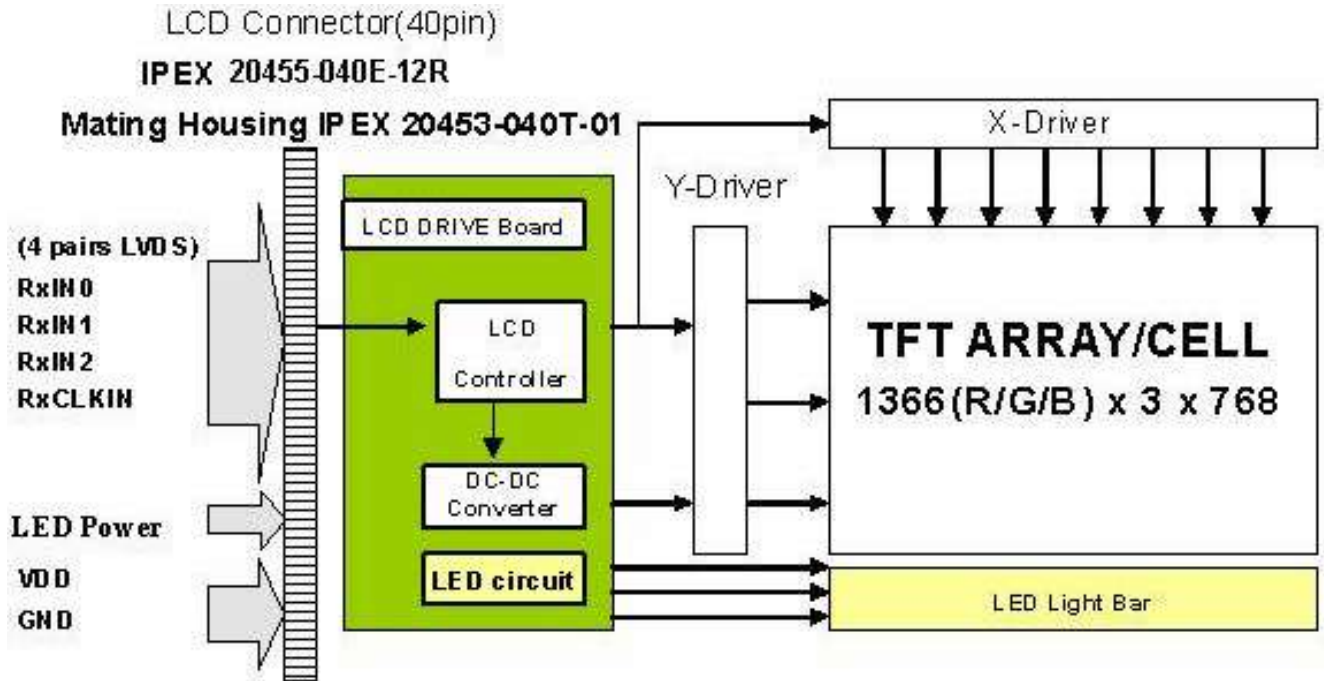

4. Absolute Maximum Ratings

An absolute maximum rating of the module is as following:

4.1 Absolute Ratings of TFT LCD Module

Item	Symbol	Min	Max	Unit	Conditions
Logic/LCD Drive Voltage	Vin	-0.3	+4.0	[Volt]	Note 1,2

4.2 Absolute Ratings of Environment

Item	Symbol	Min	Max	Unit	Conditions
Operating Temperature	TOP	0	+50	[°C]	Note 4
Operation Humidity	HOP	5	95	[%RH]	Note 4
Storage Temperature	TST	-20	+60	[°C]	Note 4
Storage Humidity	HST	5	95	[%RH]	Note 4

Note 1: At Ta (25°C)

Note 2: Permanent damage to the device may occur if exceed maximum values

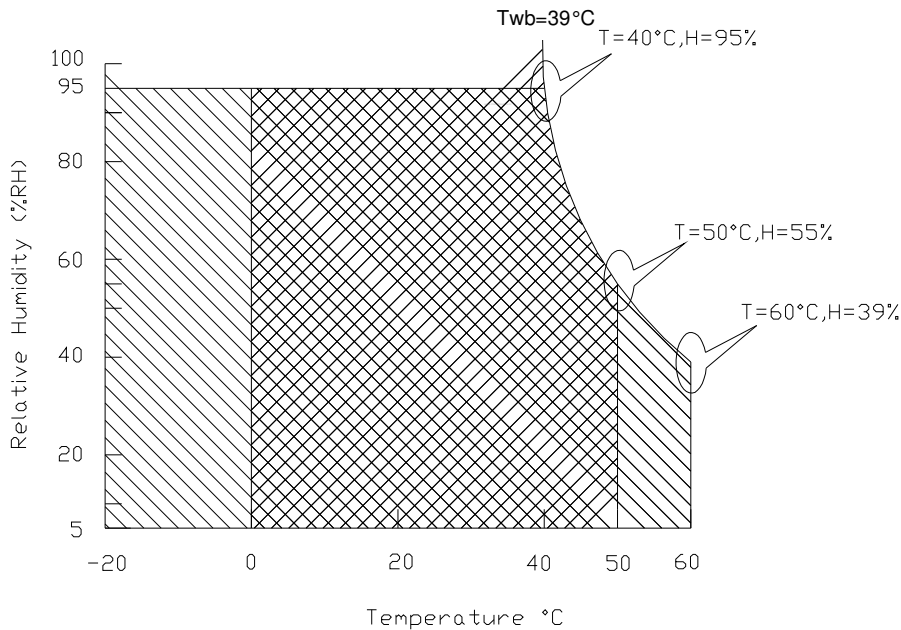

Note 3: LED specification refer to section 5.2

Note 4: For quality performance, please refer to AUO IIS (Incoming Inspection Standard).



Operating Range 

Storage Range

 + 

5. Electrical Characteristics

5.1 TFT LCD Module

5.1.1 Power Specification

Input power specifications are as follows;

The power specification are measured under 25°C and frame frequency under 60Hz

Symble	Parameter	Min	Typ	Max	Units	Note
VDD	Logic/LCD Drive Voltage	3.0	3.3	3.6	[Volt]	
PDD	VDD Power	-	-		[Watt]	Note 1
IDD	IDD Current	-	-		[mA]	Note 1
IRush	Inrush Current	-	-		[mA]	Note 2
VDDrp	Allowable Logic/LCD Drive Ripple Voltage	-	-		[mV] p-p	

Note 1 : Maximum Measurement Condition : Black Pattern at 3.3V driving voltage. ($P_{max} = V_{3.3} \times I_{black}$)

Note 2 : Measure Condition

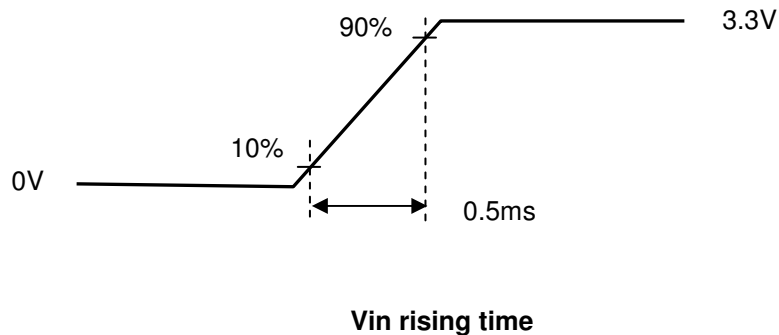
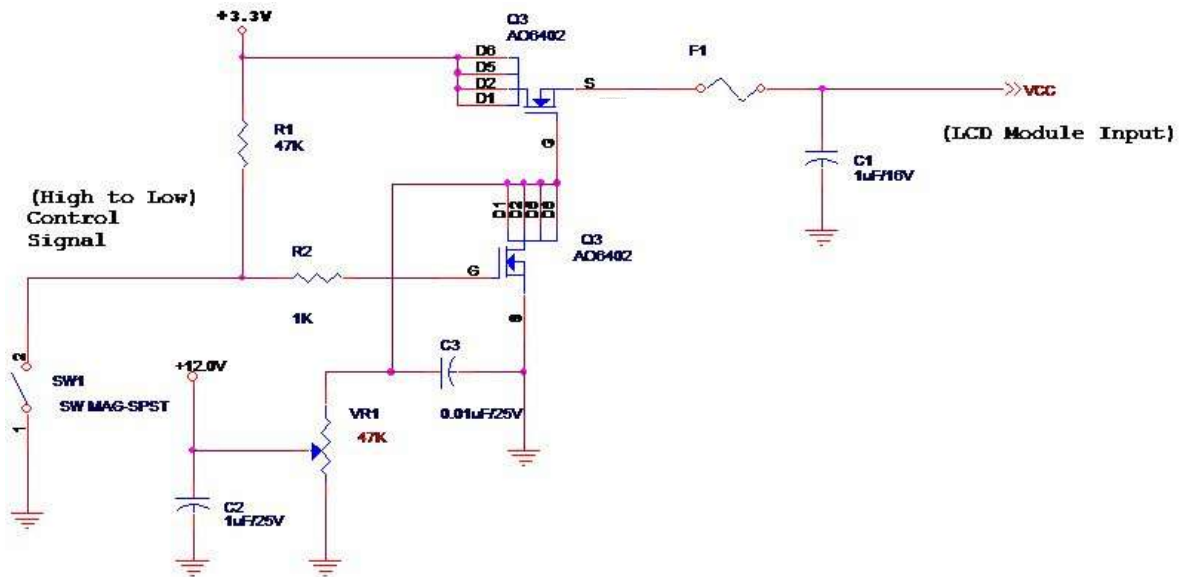

5.1.2 Signal Electrical Characteristics

Input signals shall be low or High-impedance state when VDD is off.

Signal electrical characteristics are as follows;

Parameter	Condition	Min	Max	Unit
V_{TH}	Differential Input High Threshold ($V_{cm}=+1.2V$)		100	[mV]
V_{TL}	Differential Input Low Threshold ($V_{cm}=+1.2V$)	-100	-	[mV]
$ V_{ID} $	Differential Input Voltage	100	600	[mV]
V_{CM}	Differential Input Common Mode Voltage	1.125	1.375	[V]

Note: LVDS Signal Waveform

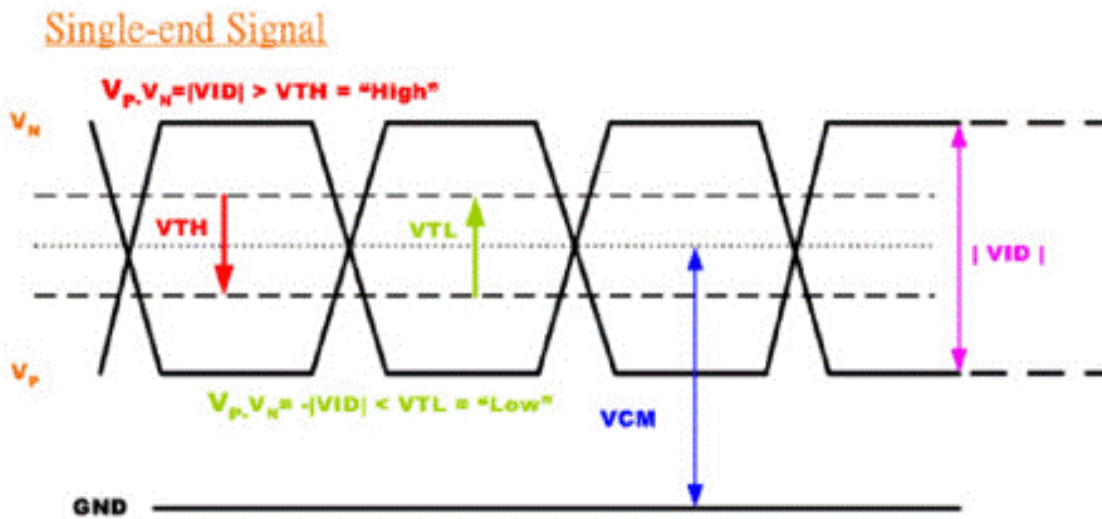

5.1.3 Color Management Characteristics

Parameter	Symbol	Min	Typ	Max	Units	Remark
Color Management Input High Level	IMG_EN	3.0	-	5.5	[Volt]	Define as Connector Interface (Ta=25°C)
Color Management Input Low Level		-	-	0.8	[Volt]	

5.1.4 Dynamic contrast ratio Characteristics

Parameter	Symbol	Min	Typ	Max	Units	Remark
Dynamic contrast ratio(DCR) Input High Level	DCR_EN	3.0	-	5.5	[Volt]	Define as Connector Interface (Ta=25°C)
Dynamic contrast ratio(DCR) Input Low Level		-	-	0.8	[Volt]	
DCR Mode Duty Index	Duty	55	-	85	%	Note 1
L0 Gray level	Power	0.45P	0.55P	0.65P	Watt	Note 2
L63 Gray level	Power	0.75P	0.85P	0.95P	Watt	

Note 1: The minimums dynamic contrast ratio is setting at darkness, and a maximum is setting at brightness.

Note 2: The power saving capability refer to original Backlight power consumption (P)



Product Specification

AU OPTRONICS CORPORATION

5.2 Backlight Unit

5.2.1 LED characteristics

Parameter	Symbol	Min	Typ	Max	Units	Condition
Backlight Power Consumption	PLED	-	-	2.2	[Watt]	(Ta=25°C), Note 1 Vin =12V
LED Life-Time	N/A	10,000	-	-	Hour	(Ta=25°C), Note 2 If=20 mA

Note 1: Calculator value for reference $P_{LED} = V_F$ (Normal Distribution) * I_F (Normal Distribution) / Efficiency

Note 2: The LED life-time define as the estimated time to 50% degradation of initial luminous.

5.2.2 Backlight input signal characteristics

Parameter	Symbol	Min	Typ	Max	Units	Remark
LED Power Supply	VLED	6.0	12.0	21.0	[Volt]	Define as Connector Interface (Ta=25°C)
LED Enable Input High Level	VLED_EN	2.5	-	5.5	[Volt]	
LED Enable Input Low Level		-	-	0.8	[Volt]	
PWM Logic Input High Level	VPWM_EN	2.5	-	5.5	[Volt]	
PWM Logic Input Low Level		-	-	0.8	[Volt]	
PWM Input Frequency	FPWM	100	-	20K	Hz	
PWM Duty Ratio	Duty	5	--	100	%	

6. Signal Interface Characteristic

6.1 Pixel Format Image

Following figure shows the relationship of the input signals and LCD pixel format.

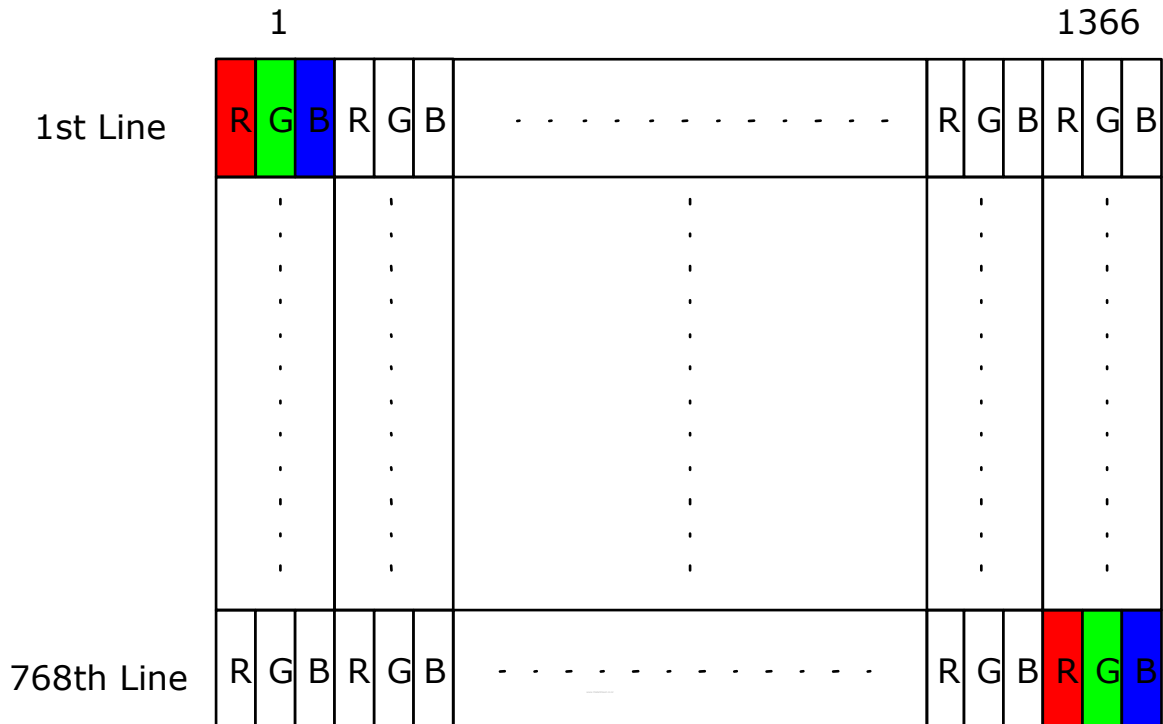

6.2 The Input Data Format

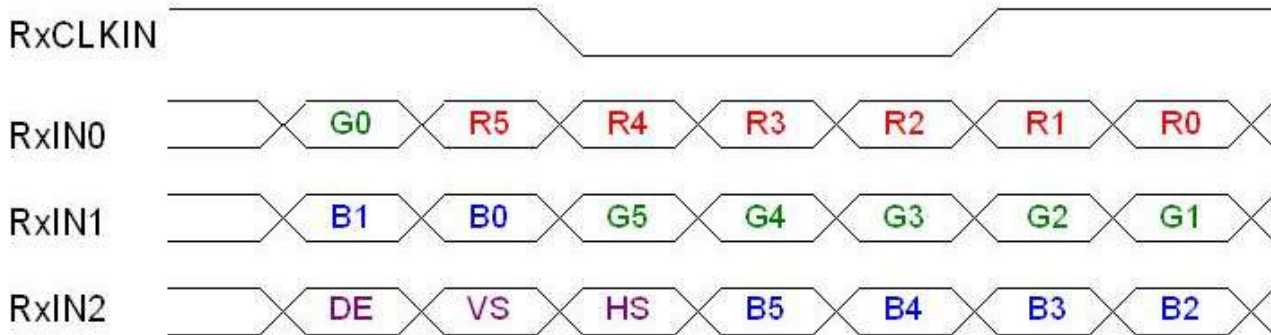

Signal Name	Description	
R5 R4 R3 R2 R1 R0	Red Data 5 (MSB) Red Data 4 Red Data 3 Red Data 2 Red Data 1 Red Data 0 (LSB)	Red-pixel Data Each red pixel's brightness data consists of these 6 bits pixel data.
G5 G4 G3 G2 G1 G0	Green Data 5 (MSB) Green Data 4 Green Data 3 Green Data 2 Green Data 1 Green Data 0 (LSB)	Green-pixel Data Each green pixel's brightness data consists of these 6 bits pixel data.
B5 B4 B3 B2 B1 B0	Blue Data 5 (MSB) Blue Data 4 Blue Data 3 Blue Data 2 Blue Data 1 Blue Data 0 (LSB)	Blue-pixel Data Each blue pixel's brightness data consists of these 6 bits pixel data.
RxCLKIN	Data Clock	The signal is used to strobe the pixel data and DE signals. All pixel data shall be valid at the falling edge when the DE signal is high.
DE	Display Timing	This signal is strobed at the falling edge of RxCLKIN. When the signal is high, the pixel data shall be valid to be displayed.
VS	Vertical Sync	The signal is synchronized to RxCLKIN .
HS	Horizontal Sync	The signal is synchronized to RxCLKIN .

Note: Output signals from any system shall be low or High-impedance state when VDD is off.



6.3 Integration Interface Requirement

6.3.1 Connector Description

Physical interface is described as for the connector on module.

These connectors are capable of accommodating the following signals and will be following components.

Connector Name / Designation	For Signal Connector
Manufacturer	IPEX or Compatible
Type / Part Number	IPEX 20455-040E-12R or Compatible
Mating Housing/Part Number	IPEX 20453-040T-11 or Compatible

6.3.2 Pin Assignment

LVDS is a differential signal technology for LCD interface and high speed data transfer device.

PIN#	Signal Name	Description
1	NC	No Connection (Reserve)
2	VDD	Power Supply +3.3V
3	VDD	Power Supply +3.3V
4	VEDID	EDID +3.3V Power
5	NC	No Connect (Reserve)
6	CLK_EDID	EDID Clock Input
7	DAT_EDID	EDID Data Input
8	RxOIN0-	-LVDS Differential Data INPUT(Odd R0-R5,G0)
9	RxOIN0+	+LVDS Differential Data INPUT(Odd R0-R5,G0)
10	VSS	Ground
11	RxOIN1-	-LVDS Differential Data INPUT(Odd G1-G5,B0-B1)
12	RxOIN1+	+LVDS Differential Data INPUT(Odd G1-G5,B0-B1)
13	VSS	Ground
14	RxOIN2-	-LVDS Differential Data INPUT(Odd B2-B5,HS,VS,DE)
15	RxOIN2+	+LVDS Differential Data INPUT(Odd B2-B5,HS,VS,DE)
16	VSS	Ground
17	RxOCKIN-	-LVDS Odd Differential Clock INPUT
18	RxOCKIN+	-LVDS Odd Differential Clock INPUT
19	IMG_EN	Color Management Input Level
20	NC	No connection
21	NC	No connection
22	NC	No connection

23	NC	No connection
24	NC	No connection
25	NC	No connection
26	NC	No connection
27	NC	No connection
28	NC	No connection
29	NC	No connection
30	NC	No connection
31	VLED_GND	LED Ground
32	VLED_GND	LED Ground
33	VLED_GND	LED Ground
34	NC	No Connection (Reserve)
35	VPWM_EN	PWM logic input level
36	VLED_EN	LED enable input level
37	DCR_EN	Dynamic Contrast Ratio Input Level
38	VLED	LED Power Supply 6V-21V
39	VLED	LED Power Supply 6V-21V
40	VLED	LED Power Supply 6V-21V

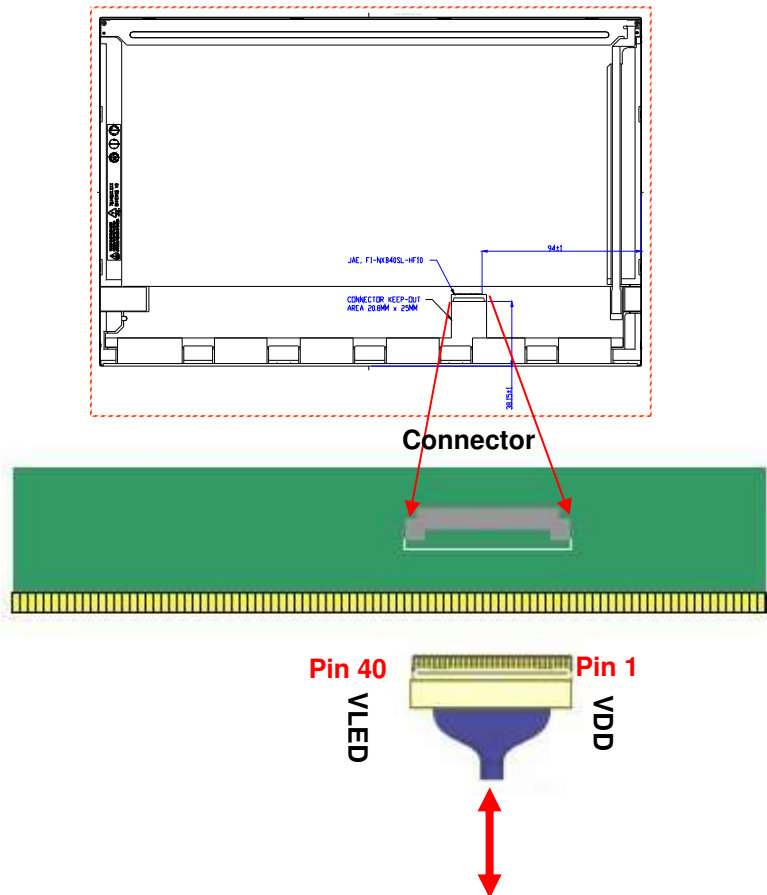

Note1: Input signals shall be low or High-impedance state when VDD is off.

6.4 Interface Timing

6.4.1 Timing Characteristics

Basically, interface timings should match the 1366x768 /60Hz manufacturing guide line timing.

Parameter	Symbol	Min.	Typ.	Max.	Unit	
Frame Rate	-	50	60	-	Hz	
Clock frequency	$1/T_{\text{Clock}}$	50	69.5	80	MHz	
Vertical Section	Period	T_V	776	790	1000	T_{Line}
	Active	T_{VD}	768			
	Blanking	T_{VB}	8	22	232	
Horizontal Section	Period	T_H	1426	1466	2000	T_{Clock}
	Active	T_{HD}	1366			
	Blanking	T_{HB}	60	100	634	

Note : DE mode only

6.4.2 Timing diagram

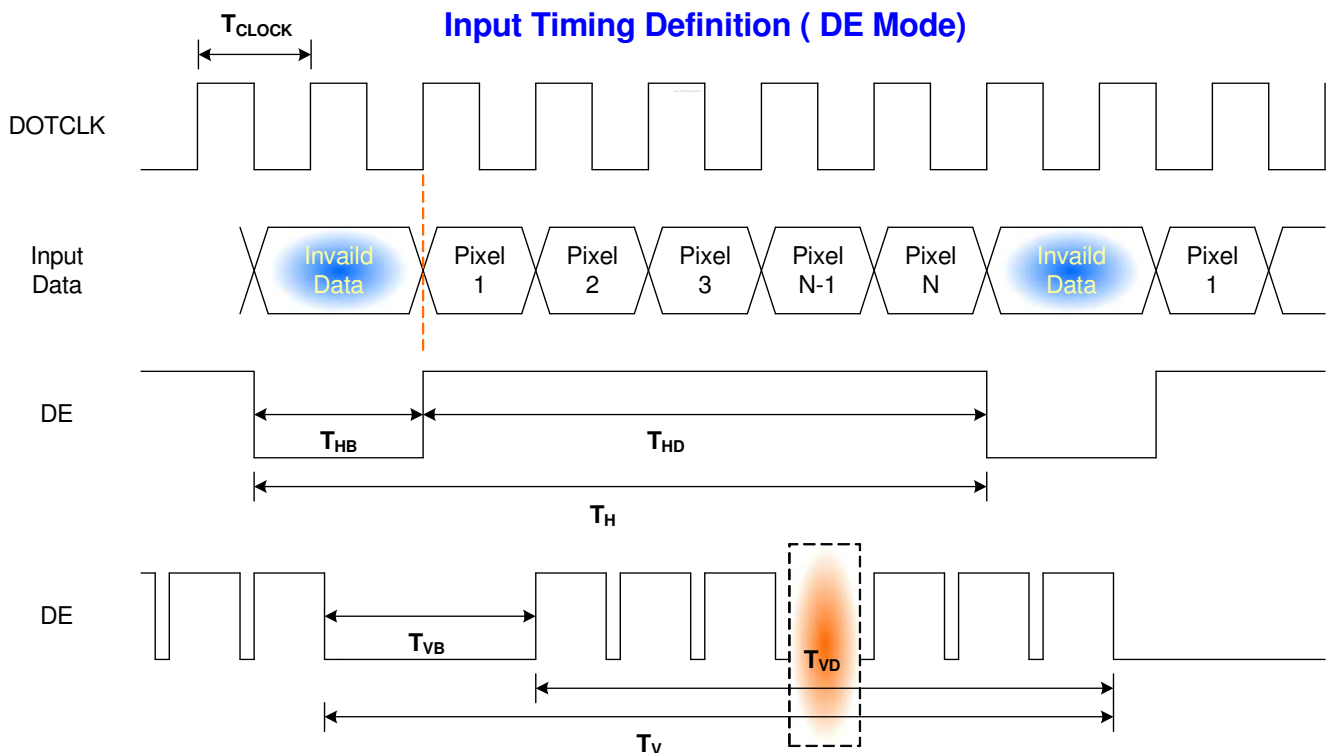

6.5 Power ON/OFF Sequence

Power on/off sequence is as follows. Interface signals and LED on/off sequence are also shown in the chart. Signals from any system shall be Hi-Z state or low level when VDD is off

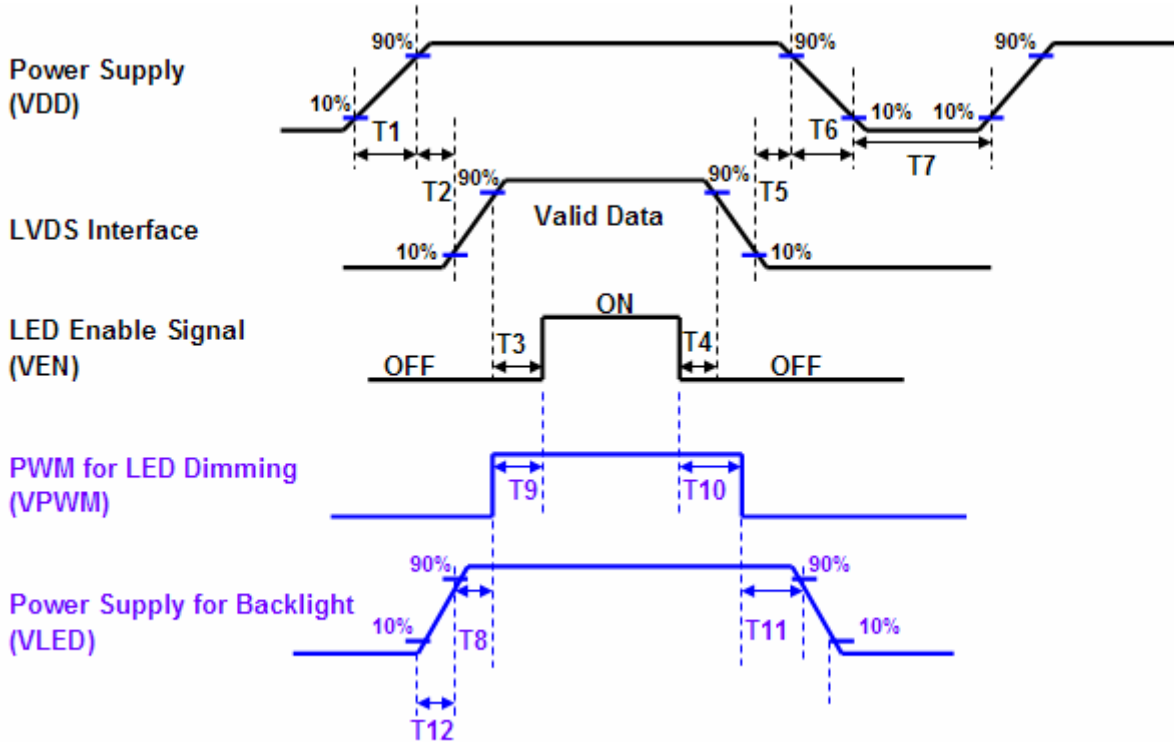

Power Sequence Timing			
Parameter	Value		Units
	Min.	Max.	
T1	0.5	10	ms
T2	0	50	
T3	200	-	
T4	200	-	
T5	0	50	
T6	0	10	
T7	500	-	
T8	10	-	
T9	0	180	
T10	0	180	
T11	10	-	
T12	0.5	10	

7. Panel Reliability Test

7.1 Vibration Test

Test Spec:

- Test method: Non-Operation
- Acceleration: 1.5 G
- Frequency: 10 - 500Hz Random
- Sweep: 30 Minutes each Axis (X, Y, Z)

7.2 Shock Test

Test Spec:

- Test method: Non-Operation
- Acceleration: 220 G , Half sine wave
- Active time: 2 ms
- Pulse: X,Y,Z .one time for each side

7.3 Reliability Test

Items	Required Condition	Note
Temperature Humidity Bias	Ta= 40°C, 90%RH, 300h	
High Temperature Operation	Ta= 50°C, Dry, 300h	
Low Temperature Operation	Ta= 0°C, 300h	
High Temperature Storage	Ta= 60°C, 35%RH, 300h	
Low Temperature Storage	Ta= -20°C, 50%RH, 250h	
Thermal Shock Test	Ta=-20°C to 60°C, Duration at 30 min, 100 cycles	
ESD	Contact : ±8 KV Air : ±15 KV	Note 1

Note1: According to EN 61000-4-2 , ESD class B: Some performance degradation allowed. Self-recoverable.

No data lost, No hardware failures.

Remark: MTBF (Excluding the LED): 30,000 hours with a confidence level 90%



Product Specification

AU OPTRONICS CORPORATION

8. Mechanical Characteristics

8.1 LCM Outline Dimension

8.1.1 Standard Front View

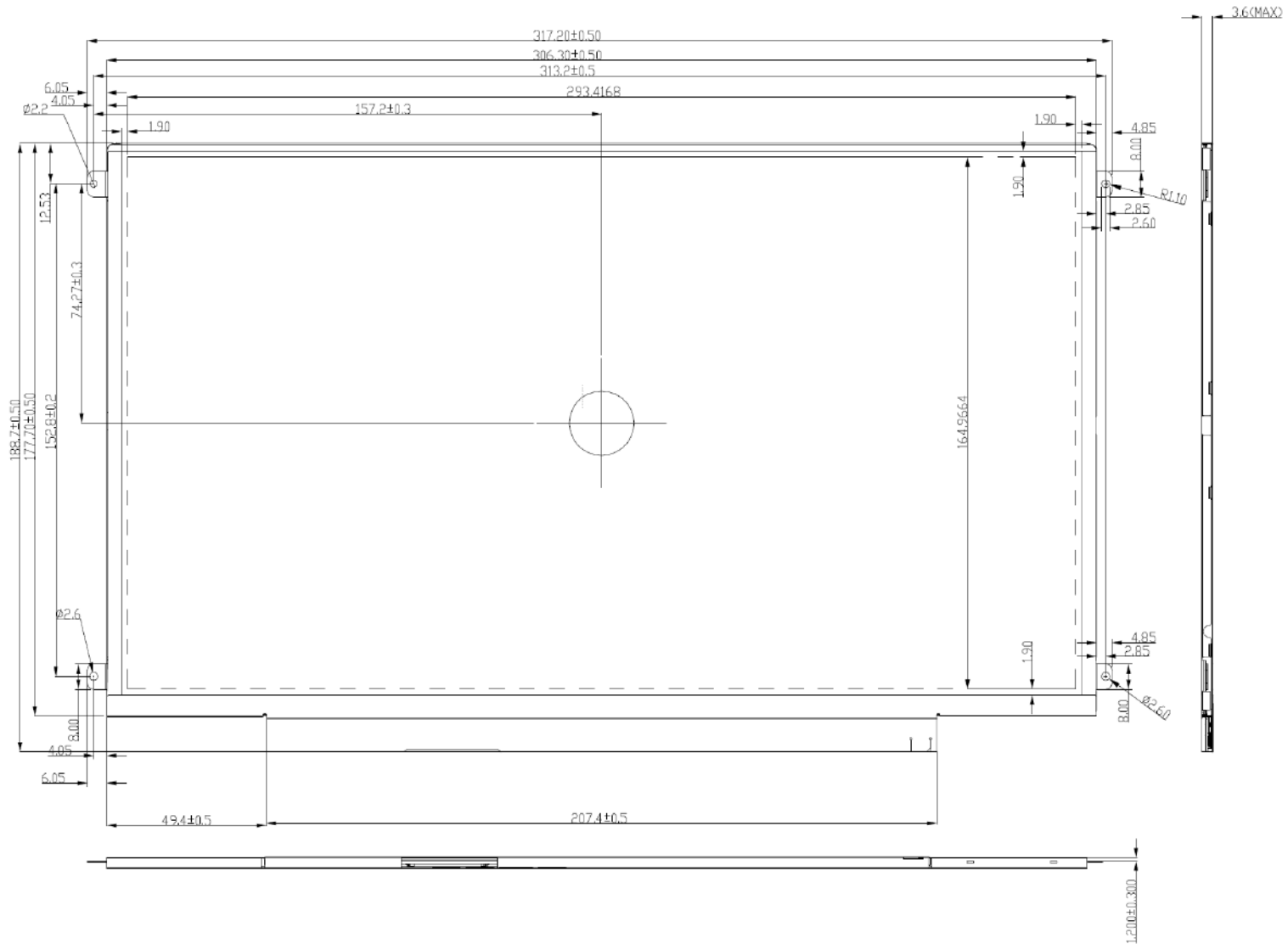

8.1.2 Standard Rear View & Key components remark and remind

Prevention damage the IC, connector, Capacitor...., we recommend your design (Ex: cable, rib, hardness parts) far away those section those have remarked at this drawing.

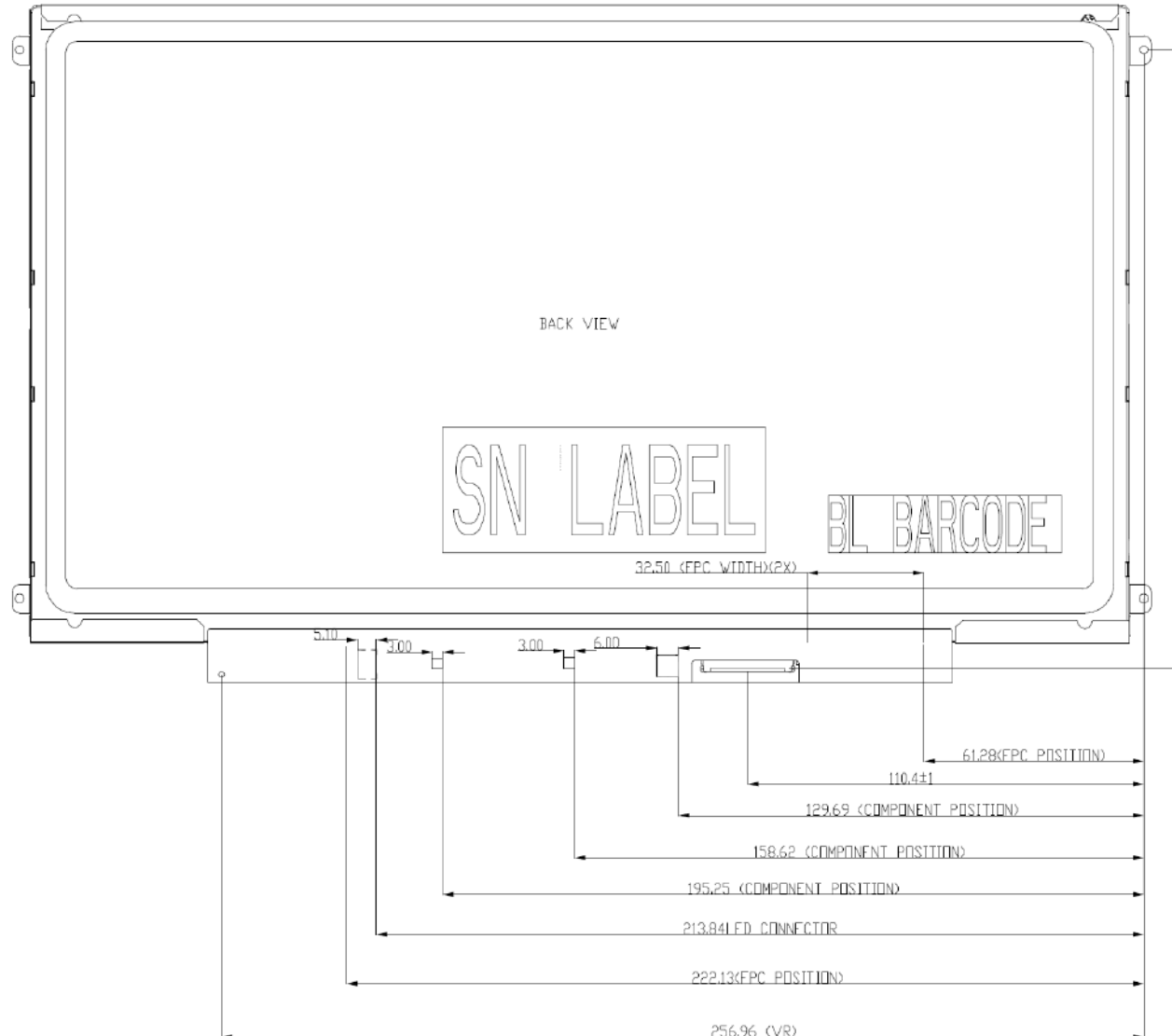

Note: Prevention IC damage, IC positions not allowed any overlap over these areas.



Product Specification

AU OPTRONICS CORPORATION

9. Shipping and Package

9.1 Shipping Label Format

	Manufactured MM/WW Model No: B133XW03 V3 AU Optronics MADE IN CHINA (S1)	
*XXXXXXXXXXXXX.XXXXXX	HW: 0A FW: 1	
		

9.2 Carton Package

The outside dimension of carton is 455 (L)mm x 380 (W)mm x 355 (H)mm

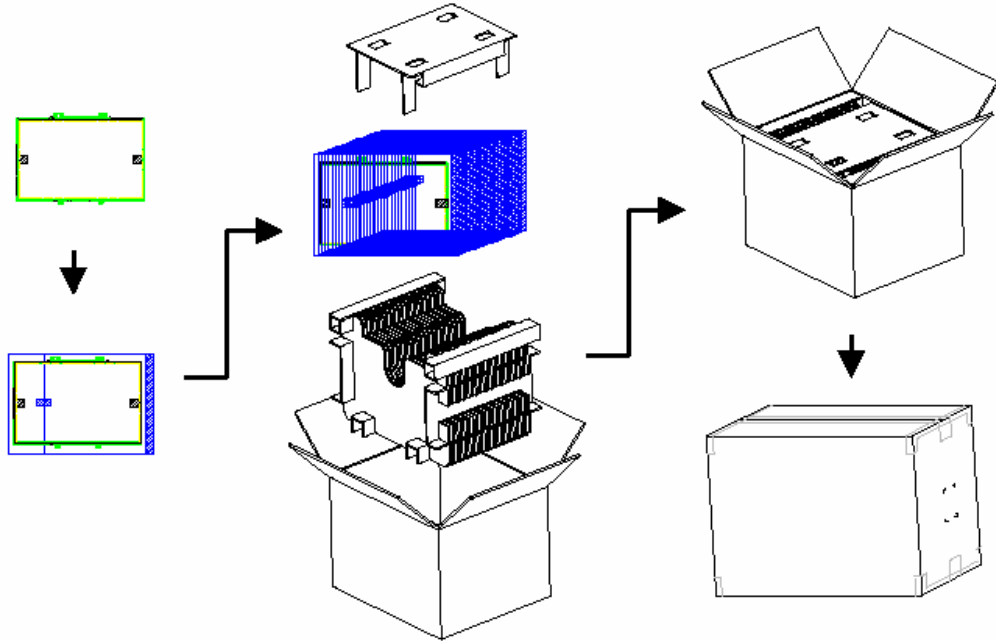

9.3 Shipping Package of Palletizing Sequence

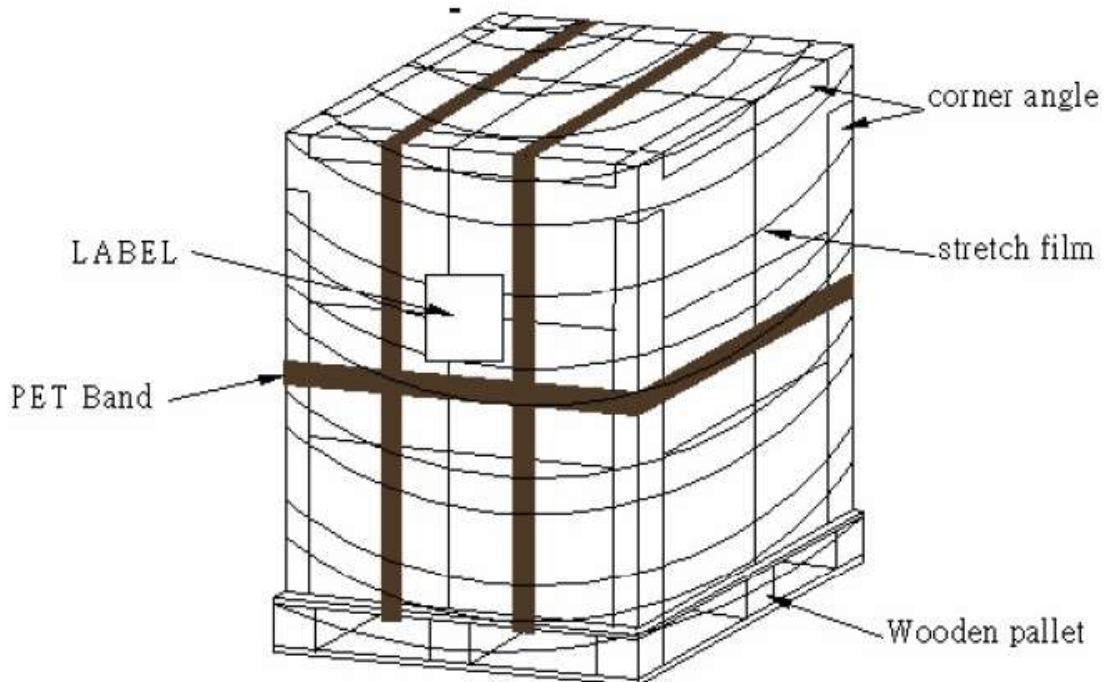



10. Appendix

10.1 EDID Description

Address	FUNCTION	Value	Value	Value	Note
HEX		HEX	BIN	DEC	
00	Header	00	00000000	0	
01		FF	11111111	255	
02		FF	11111111	255	
03		FF	11111111	255	
04		FF	11111111	255	
05		FF	11111111	255	
06		FF	11111111	255	
07		00	00000000	0	
08	EISA Manuf. Code LSB	06	00000110	6	
09	Compressed ASCII	AF	10101111	175	
0A	Product Code	2C	00101100	44	
0B	hex, LSB first	33	00110011	51	
0C	32-bit ser #	00	00000000	0	
0D		00	00000000	0	
0E		00	00000000	0	
0F		00	00000000	0	
10	Week of manufacture	00	00000000	0	
11	Year of manufacture	13	00010011	19	
12	EDID Structure Ver.	01	00000001	1	
13	EDID revision #	03	00000011	3	
14	Video input def. (digital I/P, non-TMDS, CRGB)	80	10000000	128	
15	Max H image size (rounded to cm)	1D	00011101	29	
16	Max V image size (rounded to cm)	10	00010000	16	
17	Display Gamma (=gamma*100)-100	78	01111000	120	
18	Feature support (no DPMS, Active OFF, RGB, tmg Blk#1)	0A	00001010	10	
19	Red/green low bits (Lower 2:2:2:2 bits)	15	00010101	21	
1A	Blue/white low bits (Lower 2:2:2:2 bits)	85	10000101	133	
1B	Red x (Upper 8 bits)	97	10010111	151	
1C	Red y/ highER 8 bits	58	01011000	88	
1D	Green x	53	01010011	83	
1E	Green y	8A	10001010	138	
1F	Blue x	26	00100110	38	
20	Blue y	25	00100101	37	



Product Specification

AU OPTRONICS CORPORATION

21	White x	50	01010000	80
22	White y	54	01010100	84
23	Established timing 1	00	00000000	0
24	Established timing 2	00	00000000	0
25	Established timing 3	00	00000000	0
26	Standard timing #1	01	00000001	1
27		01	00000001	1
28	Standard timing #2	01	00000001	1
29		01	00000001	1
2A	Standard timing #3	01	00000001	1
2B		01	00000001	1
2C	Standard timing #4	01	00000001	1
2D		01	00000001	1
2E	Standard timing #5	01	00000001	1
2F		01	00000001	1
30	Standard timing #6	01	00000001	1
31		01	00000001	1
32	Standard timing #7	01	00000001	1
33		01	00000001	1
34	Standard timing #8	01	00000001	1
35		01	00000001	1
36	Pixel Clock/10000 LSB	26	00100110	38
37	Pixel Clock/10000 USB	1B	00011011	27
38	Horz active Lower 8bits	56	01010110	86
39	Horz blanking Lower 8bits	64	01100100	100
3A	HorzAct:HorzBlnk Upper 4:4 bits	50	01010000	80
3B	Vertical Active Lower 8bits	00	00000000	0
3C	Vertical Blanking Lower 8bits	16	00010110	22
3D	Vert Act : Vertical Blanking (upper 4:4 bit)	30	00110000	48
3E	HorzSync. Offset	30	00110000	48
3F	HorzSync.Width	20	00100000	32
40	VertSync.Offset : VertSync.Width	36	00110110	54
41	Horz&Vert Sync Offset/Width Upper 2bits	00	00000000	0
42	Horizontal Image Size Lower 8bits	25	00100101	37
43	Vertical Image Size Lower 8bits	A4	10100100	164
44	Horizontal & Vertical Image Size (upper 4:4 bits)	10	00010000	16
45	Horizontal Border (zero for internal LCD)	00	00000000	0
46	Vertical Border (zero for internal LCD)	00	00000000	0
47	Signal (non-intr, norm, no stero, sep sync, neg	18	00011000	24



Product Specification

AU OPTRONICS CORPORATION

	pol)				
48	Detailed timing/monitor	00	00000000	0	
49	descriptor #2	00	00000000	0	
4A		00	00000000	0	
4B		0F	00001111	15	
4C		00	00000000	0	
4D		00	00000000	0	
4E		00	00000000	0	
4F		00	00000000	0	
50		00	00000000	0	
51		00	00000000	0	
52		00	00000000	0	
53		00	00000000	0	
54		00	00000000	0	
55		00	00000000	0	
56		00	00000000	0	
57		00	00000000	0	
58		00	00000000	0	
59		20	00100000	32	
5A	Detailed timing/monitor	00	00000000	0	
5B	descriptor #3	00	00000000	0	
5C		00	00000000	0	
5D		FE	11111110	254	
5E		00	00000000	0	
5F	Manufacture	41	01000001	65	A
60	Manufacture	55	01010101	85	U
61	Manufacture	4F	01001111	79	O
62		0A	00001010	10	
63		20	00100000	32	
64		20	00100000	32	
65		20	00100000	32	
66		20	00100000	32	
67		20	00100000	32	
68		20	00100000	32	
69		20	00100000	32	
6A		20	00100000	32	
6B		20	00100000	32	
6C	Detailed timing/monitor	00	00000000	0	
6D	descriptor #4	00	00000000	0	



Product Specification







AU OPTRONICS CORPORATION

6E		00	00000000	0	
6F		FE	11111110	254	
70		00	00000000	0	
71	Manufacture P/N	42	01000010	66	B
72	Manufacture P/N	31	00110001	49	1
73	Manufacture P/N	33	00110011	51	3
74	Manufacture P/N	33	00110011	51	3
75	Manufacture P/N	58	01011000	88	X
76	Manufacture P/N	57	01010111	87	W
77	Manufacture P/N	30	00110000	48	0
78	Manufacture P/N	33	00110011	51	3
79	Manufacture P/N	20	00100000	32	
7A	Manufacture P/N	56	01010110	86	V
7B	Manufacture P/N	33	00110011	51	3
7C		20	00100000	32	
7D		0A	00001010	10	
7E	Extension Flag	00	00000000	0	
7F	Checksum	47	01000111	71	

10.2 Color Standardization Photographs

Standardization photographs have declared by AUO

TFT panel character has corresponding with photographs optimum setting

<p>Darkness Pattern</p>	 <p>Darkness-1</p>					
<p>Brightness Pattern</p>	 <p>Brightness-1</p>		 <p>Brightness-2</p>			
<p>Text Optimization</p>	 <p>Texture Optimum-1</p>		 <p>Texture Optimum-2</p>			
<p>High Contrast Ratio Pattern</p>	 <p>High contrast ratio-1</p>	 <p>High contrast ratio-2</p>	 <p>High contrast ratio-3</p>	 <p>High contrast ratio-4</p>		
<p>Visual High Color Saturation</p>	 <p>Visual high color-1</p>	 <p>Visual high color-2</p>	 <p>Visual high color-3</p>	 <p>Visual high color-4</p>	 <p>Visual high color-5</p>	
<p>Sharpness Pattern</p>	 <p>Sharpness-1</p>	 <p>Sharpness-2</p>	 <p>Sharpness-3</p>	 <p>Sharpness-4</p>	 <p>Sharpness-5</p>	 <p>Sharpness_8</p>